



Model

MP7

Product Description

Planetary Mixer, 7 litre, Heavy Duty

Product Code

5MP7

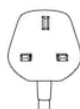

Standard Features

- Heavy duty 7ltr, counter-top, planetary mixer
- Particularly suitable for bakeries, hotels, restaurants, canteens etc
- Easy to operate
- Planetary mixing action ensures perfect results
- High torque 600w motor allows mixing of stiffer doughs and larger batches
- Automatic electronic 5-speed control and digital timer
- 5 Variable speeds from 193 rpm to 495 rpm
- Non-stop shifting speed
- 30 minute timer
- Interlocking bowl guard and bowl lift
- Perspex safety guard with ingredient chute and automatic shut-off when guard is opened at any speed
- Overload protection (NVR device)
- Long lasting lubricant providing abrasion resistant transmission
- Transmission gears are made of heat treated, hardened steel
- All metal and die-cast aluminium body
- Quiet operation

Standard Accessories / Attachments

- 1 x Whisk
- 1 x Beater
- 1 x Dough Hook
- 1 x 7 litre stainless steel bowl

Warranty

Covered by Metcalfe 3-year warranty (1st year parts and labour, 2nd & 3rd years parts only) and full after sales service

Optional Accessories / Attachments

Item	Product Code
Bowl	MP11007-12-001
Beater	MP11007-12-002

Item	Product Code
Dough Hook	MP11007-12-003
Whisk	MP11007-12-004

Drawing

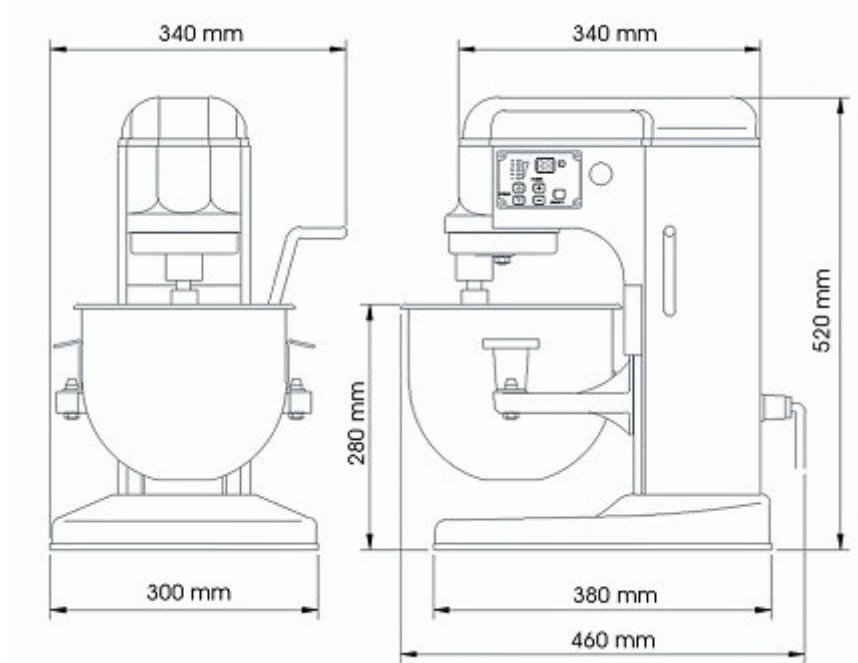

Specifications

Model	Capacity (ltr)	Phase (Ø)	Motor (Volt)	Frequency (Hz)	Power (kW)	Speed (rpm)
MP7	7	1	220-240	50	0.60	193-495

Dimensions | Shipping Information

Model	Overall Dimensions D x W x H (mm)	Net Weight (kg)	Packed Dimensions D x W x H (mm)	Packed Weight (kg)	Volume (m3)
MP7	460 x 340 x 520	18	510 x 400 x 610	20	0.124

We reserve the right to alter the specification and technical details for this item at any time without prior notice. 05/2021

Metcalfe Catering Equipment Ltd

Haygarth Park
Blaenau Ffestiniog
Gwynedd, LL41 3PF

